

# Ethernet I/O: EtherStax® Series

## ES2113 Ethernet Discrete I/O Modules

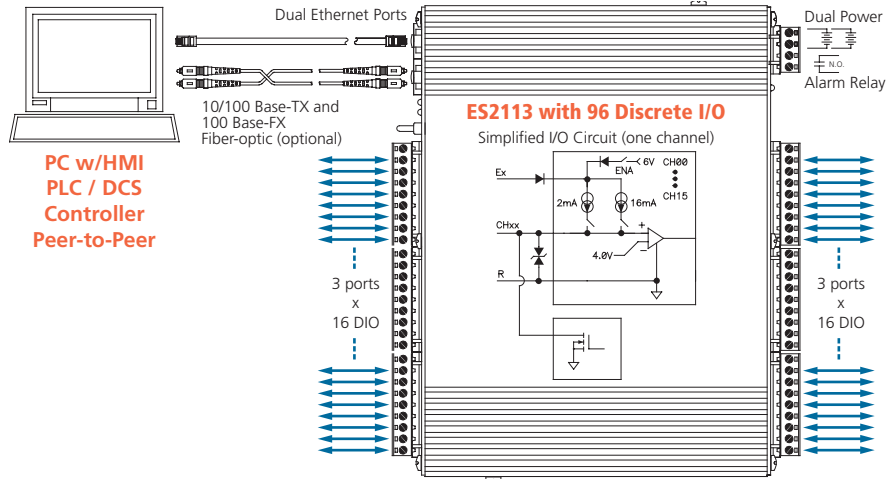

### 96 bi-directional discrete I/O channels ♦ Modbus TCP/IP, i2o peer-to-peer communication

#### Description

EtherStax I/O blocks provide a ruggedized, high-density solution to interface a very large quantity of discrete I/O signals to your control system. A stackable aluminum housing maintains a small footprint and stands up to harsh, industrial environments. Web-based configuration simplifies setup with any web browser.

#### Input Ranges

0 to 28V DC, active-low inputs

#### Output Range

0 to 28V DC (0.5A/ch) low-side switches

#### Ethernet Communication

10/100Base-T(X) and 100Base-FX  
Modbus TCP/IP or UDP/IP protocol  
Acromag i2o® peer-to-peer technology

#### Power Requirement

18 to 36V DC (redundancy-ready)

#### Approvals

CE, UL, & cUL listed  
Class 1; Division 2; Groups A, B, C, D.

- **96 discrete I/O channels:**  
Bi-directional channels support any input/output mix in a single unit.
- **High-density stackable unit:**  
Stacked mounting puts a lot of I/O in a very small footprint to save panel space.
- **High Speed Channel Updates:**  
Updates all 96 channels in 1mS.
- **Modbus TCP/IP or UDP/IP protocol:**  
I/O functions as slave to host controller.
- **Peer-to-peer i2o communication:**  
Inputs to one unit automatically update outputs on another over Ethernet link.
- **Change-of-state or timed updates:**  
Event-driven updates transmit data in less than 5mS between peers with i2o.
- **10 Modbus TCP/IP sockets/sessions:**  
Multiple masters can talk to an EtherStax unit at the same time.
- **Self-test checks I/O operation:**  
Test I/O channels from a web browser before wiring terminals to devices.
- **Selectable input "wetting" current:**  
Internal current source eliminates pull-ups and improves dry contact interface.
- **Automatic change of state detection:**  
Inputs detect quick momentary changes of state that occur between polling.
- **Internal or external port excitation:**  
Selectable source on each 16-channel port simplifies wiring and adds flexibility for use with 5-28V DC logic.
- **Loop-back monitoring on all channels:**  
Inputs confirm output states for increased system reliability.
- **Watchdog timers and failsafe outputs:**  
Communication fault sends output to a pre-defined state or holds the last value.
- **Output open-load detection:**  
Output fault detection is selectable on individual channels.
- **Thermal, current, voltage protection:**  
I/O is protected from excessive levels to reduce downtime.



Open circuit board versions also available.





## Performance Specifications

### ◆ General Specifications

See Page 7 for communication and other specs.

### ◆ Inputs

#### Configuration (active-low inputs)

96 channels (six 16-ch ports) with a common return (RTN). Each input is connected in tandem with open-drains of output mosfets. Any mix of I/O occurs as all channels are high impedance inputs unless written. Output channels can be read back at any time (loop-back monitoring).

#### Input Signal Voltage Range

0 to 28VDC, 31V maximum. Surge protected.

#### Input Threshold Detection and Sensitivity

4V DC threshold. Level or latching inputs.

#### Input "Wetting" Current

Built-in current sources switch from 16mA initially (20ms) to 2mA (continuous), default mode. Sources can be changed to 2mA or turned off.

#### Excitation

Internal (default): 6V DC, 400mA.

External: 6 to 28V DC typical. Separate excitation terminal (logic) for each 16-channel port. Internal and external supplies are diode-blocked from each other. Includes reverse polarity protection.

#### Peer-to-peer (i2o) communication

Change-of-state updates: Less than 5ms events.  
Timed updates: Configurable for 1-90 seconds.

### ◆ Outputs

#### Configuration (low-side switches)

96 channels (six 16-ch ports) of open-drain mosfet switches with common source connection at port RTN terminal. Each output is connected in tandem with buffered inputs.

#### Output "OFF" Voltage Range

0 to 28V DC, 31V maximum. Surge protected.

#### Output "ON" Current Range

0 to 300mA DC continuous, each output.

#### Output "ON" Maximum Current

450mA DC maximum with any 8 channels "on" continuously per 16 channel port

#### Output Port Maximum Current

4.8A: 16 channels @ 300mA continuous  
3.6A: 8 channels "off" & 8 channels @ 450mA

### ◆ Local Alarm Output

#### Configuration

Isolated relay de-energizes (failsafe) or energizes (non-failsafe) as configured when the watchdog timer detects a media or communication failure.

#### Type

SPST-NO, 1 Form A, Class I, Division II approved.

#### Rating

5A @ 24VDC/250VAC, 6000 cycles resistive.  
3A @ 24VDC/250VAC, 100,000 cycles general.  
2A @ 24VDC/250V AC, Hazardous locations

#### Maximum Switching Voltage

250VAC, 125VDC.

### ◆ Enclosure and Physical

#### Housing Classification and Dimensions

IP20: 8.226" x 2.444" x 7.25"  
4 lbs. (1.8 kg) packed (unit weighs 3.4 lbs).  
Without enclosure: 7.920" x 1.875" x 7.25".  
1.65 lbs. (0.75 kg) packed (unit weighs 1.05 lbs).

#### Safety Approvals

CE marked and UL/cUL Listed.

Hazardous Locations: Class 1; Div. 2; A B C D.

Open board units: UL Recognized

#### Shock and Vibration Immunity

Rating for single surface-mount unit in enclosure.

Mechanical Shock: 50g, 3ms, with 3 half-sine shock pulses in each direction along 3 axes (18 shocks), and 30g, 11ms, with 3 half-sine shock pulses in each direction along 3 axes (18 shocks), per IEC60068-2-27.

Random Vibration: 5g, 5-500Hz, in 3 axes at 2 hours/axis per IEC60068-2-64.

### ◆ Environmental

#### Operating and Storage Temperature

Operating: Open bd, -40 to 75°C (-40 to +167°F)  
Enclosed bd, -40 to 75°C (all outputs "off")  
-40 to 70°C (all outputs "on" at rated Max.).  
Storage: -40 to +85°C (-40 to +185°F).

#### Power Requirements

18-36V DC. Redundant, diode-coupled terminals.  
Dual copper ports: 2.5W with external excitation, 3.5W with internal excitation.  
Fiber optic units: Call factory.

#### Isolation

I/O, power, relay and Ethernet port-to-port.  
Peak: 1500V AC, ANSI/ISA-82.01-1988.  
Continuous: 250V AC, 354V DC.

### ◆ Ethernet Interface

#### Internal Switch or Hub/Repeater

Dual-port Ethernet switch. Web-configurable as a true switch (default mode) or hub.

#### Network Connector [10/100 Base-T(X)Copper]

One or two 8-pin RJ-45 connectors. Automatic MDI/MDI-X. 100m communication distance.

#### Network Connector (100 Base-FX Fiber-optic)

One multi-mode with SC connector. 2km communication distance. Full/half-duplex, selectable.

#### Protocols and Addressing

Modbus TCP/IP or UDP/IP. i2o peer-to-peer. StaticIP, DHCP, BootP. Configurable IP addresses.

#### Ethernet Modbus TCP/IP Sockets/Sessions

1-10 socket/sessions programmable via web page.

#### Ethernet Redundancy

Compatible with STP, RSTP, proprietary schemes.

## Ordering Information

### ◆ I/O Modules

#### ES2113-0000

96 DIO, two copper ports, IP20 enclosure

#### ES2113-0010

96 DIO, two copper ports, open circuit board

#### ES2113-1000

96 DIO, one Cu & one fiber port, IP20 enclosure

#### ES2113-1010

96 DIO, one Cu & one fiber port, open board

### ◆ Accessories

#### Industrial Ethernet Switches

See Page 33.

#### Hardware Accessories and Power Supplies

See Page 34.

#### Software Support

See Page 36.